



Original scientific paper

UDC: 911.3:338.48

<https://doi.org/10.2298/IJGI2003273B>

Received: August 28, 2020

Reviewed: November 11, 2020

Accepted: December 1, 2020



THE IMPACTS OF SECOND HOME TOURISM ON SOCIO-CULTURAL AND ECONOMIC LIFE: THE RESIDENTS' PERSPECTIVES

Furkan Baltacı¹, Aydin Cevirgen^{2}*

¹Independent Researcher, Alanya, Turkey; e-mail: furkan_baltaci@hotmail.com

²Alanya Alaaddin Keykubat University, Tourism Faculty, Tourism Management Department, Alanya, Turkey; e-mail: aydin.cevirgen@alanya.edu.tr

Abstract: The aim of the study is to determine the perceptions of permanent residents on the impact of foreign second home owners on the socio-cultural and economic life of the city, and the residents' level of satisfaction in terms of living with them. As part of the research, a questionnaire study was carried out with 453 residents who reside in areas where there is a predominance of second home owners. The Second Home Tourism Impact Scale (SHTIS) was developed to measure the impacts of second home owners. In the results of the exploratory factor analysis (EFA), four main factors were identified to be associated with residents' perceptions of the socio-cultural and economic impacts of second home owners. These factors included socio-cultural benefit, socio-cultural cost, economic benefit, and economic cost. These factors were then affirmed by confirmatory factor analysis (CFA). According to the main findings of the study, the residents believe that while foreign owners increase the economic costs, they also generate major economic benefits to their lives. In terms of socio-cultural aspects, they stated that second homes owners caused more positive effects compared to the negative ones. Moreover, it was identified that although the residents are not dissatisfied with the foreign owners, they do not support the foreign owners to have more estates and be entitled to easier conditions to buy them.

Keywords: second home tourism; socio-cultural impact; economic impact; permanent residents

Introduction

Today, as unemployment rates and cost of living have increased and dramatic changes have taken place in weather and environmental conditions, people have been driven to relocate, the result of which has been an increase in migrations between regions, countries, and continents (Podra, Levkiv, Koval, Petryshyn, & Bobko, 2020; Van Hear, Bakewell, & Log, 2018). Certainly, migrations can simply be motivated by the desire to improve the social status and other arbitrary reasons. These latter migrations are related to tourism (Breuer, 2005) and are commonly seen in societies which have high levels of economic welfare and standards of living (Lanzara & Minerva, 2019). Reasons associated with climate conditions, living standards and the desire to have homes near the seaside govern the desire of the people who live in these societies to have estates in other regions or countries (Abdul-Aziz, Loh, & Jaafar, 2014; Wong & Musa, 2017). These estates largely serve as second homes, which variably are referred to as vacation homes, recreational homes, summer homes, weekend homes, and cottages.

*Corresponding author, e-mail: aydin.cevirgen@alanya.edu.tr

The second homes range in type from non-mobile apartments, villas, and semi-mobile caravans to tents and movable sailing boats (Hall & Müller, 2004).

The purchase or rental of estates in any destinations by foreigners has led to the emergence of second home tourism (Nouza, Ólafsdóttir, & Sæþórsdóttir, 2018; Williams, King, Warnes, & Patterson, 2000). As part of the accommodation sector, second homes feature strongly in modern tourism, for domestic and foreign tourists alike. They, therefore, contribute to the regional economies in most tourism destinations (Hall & Müller, 2004). This situation in and of itself has resulted in the growth of the second home tourism industry. Today, one of the most popular destinations for second homes is the Mediterranean tourist region because of its numerous tourist attractions (Farstad, 2018).

In the literature on the subject, studies focus heavily on the second home development and their environmental, social, cultural, and economic impacts (Brida, Osti, & Santifaller, 2011; Gallent, 2014; Hall & Müller, 2004; Hiltunen, 2007; Marjavaara & Müller, 2007; Müller, 2006; 2007; 2011a; Müller & Hoogendoorn, 2013; Nouza, Ólafsdóttir, & Müller, 2013; Overvåg, 2011; Tress, 2002). The majority of empirical studies on these subjects were conducted using the perspectives of second home owners (Dias, Correia, & Lopez, 2015; Kaltenborn, Andersen, Nelleman, Bjerke, & Thrane, 2008; McLeod & Busser, 2014; Müller, 2002a; 2011b; Norris & Winston, 2010). More recently, however, some studies have focused on the perspectives of local authorities (Roca, Oliveria, Roca, & Costa, 2012), and a few have applied qualitative (Barnett, 2014; Farstad, 2011; Litvin, Xu, Ferguson, & Smith, 2013) and quantitative approaches (Kaltenborn et al., 2008; Perles-Ribes, Ramón-Rodríguez, Moreno-Izquierdo, & Such-Devesa, 2020; Radulescu, 2014) in their research on this subject.

The use of second homes in tourism has been gradually increasing as of late (Soto & Clavé, 2018). The literature on the subject presents various theoretical studies on the development and impacts of second homes. The majority of empirical studies conducted on the subject have not taken into account the perspective of permanent residents, but instead have focused strictly on the perspectives of second home owners, particularly those residing in the countryside. This study featured three main research questions: What kind of impacts do foreign second home owners have on city life?; What degree of satisfaction do the residents have in living with foreign second home owners?; and Do permanent residents' perceptions on the impacts of second home tourism affect their satisfaction level? This research was conducted based on residents' perspectives in Alanya, an important mass tourism destination of Turkey and the Mediterranean Tourist Region. According to the research findings, which are supported by the available literature, some recommendations were made to the relevant stakeholders and future research.

Second home tourism

Although such terms as recreational homes, vacation homes, summer homes, and weekend homes are used interchangeably in the literature, applied individually, they fail to fully define the second home concept, as the concept includes all of these terms (Hall & Müller, 2004). Nonetheless, considering the similarities between the terms, the second home can be defined as a dwelling, used by owners or other people for a certain period of time, that is bought or rented for vacation or recreational purposes and does not have the status of being a permanent home. The difficulties involved in adequately defining second homes result in their diverse categorizations. Baud-Bovy and Lawson (1977) categorized second homes according to their distance from permanent homes and the duration and frequency of use. In another categorization, they were separated into three

classes as non-mobile (stand-alone cottages and houses, etc.), semi-mobile (caravans, tents, etc.), and mobile (sail boats) (Newig, 2000, as cited in Hall & Müller, 2004).

The relationship of second homes to tourism is highlighted in most definitions and categorizations. However, they started to be used as an overnight stay in tourism such as caravans, holiday camps, and self-catering accommodations (Statista, 2018). Furthermore, studies related to second homes in the literature show that they have become an essential part of tourism (Brida et al., 2011; Dias et al., 2015; Hiltunen, 2007; Jaakson, 1986; Kaltenborn et al., 2008; Müller, 2002a, 2002b; Müller, Hall, & Keen 2004; Radulescu, 2014; Roca et al., 2012; Tress, 2002). Second home tourism is a type of tourism that has materialized as a result of the purchase or rental of second homes for recreational purposes by owners, their relatives, and friends or vacationers. This kind of tourism includes all the options related to travels and overnight stays (Tress, 2002). As a result of this mobility, people from different cultures are able to come together and interact in various social, cultural and economic areas. This interaction also includes the one which takes place between second home owners and permanent residents. Within this study, the interaction between permanent residents and foreign second home owners was highlighted.

Interaction between residents and second home owners

The purchase of second homes throughout numerous countries of the world leads to the interaction between many different cultures. Since second home owners are regarded as tourists, it is not always easy to distinguish the interaction between residents and second home owners and tourists-residents' interaction (Brida et al., 2011; Tuulentie & Kietäväinen, 2020). However, second home tourism does have distinctive features. Most importantly, the second home owners become part of the local community (Müller, 2002a). Therefore, a multidimensional interaction occurs between permanent residents and foreign owners in socio-cultural and economic terms.

Socio-cultural interaction

There are many pros and cons for both sides in the interaction between residents and second home owners. On the positive side, the interaction facilitates the breaking down of prejudices, and in the second home owners' desire to learn the local language in order to communicate with the local people, they can establish closer ties with the local community (Adamiak, 2018). In more economic terms, when foreigners start buying houses in an area, an acceleration in infrastructure investment (water, electricity, health, education, etc.) takes place, which in turn serves to improve the quality of life for the residents (Kaltenborn et al., 2008; Roca et al., 2012). As the communicative ability of the residents gradually improves through their interaction with foreigners, their self-confidence is raised and they are able to gain valuable international human relations experience (Kaltenborn et al., 2008). Also, the second home owners live side by side with the permanent residents, neighborly relationships can be formed, and the social environment for both is enlarged (Litvin et al., 2013).

Another important interaction in the social life constituting the dynamics of second home owners and permanent residents is the marriages entered into with foreign second home owners. These marriages, however, can have not only positive but also negative results. For example, if the couple should divorce for any reason, the children can be negatively affected and social problems can arise (Wong & Musa, 2017). Sometimes disagreements between permanent residents and second home owners can crop up, and social conflicts can occur among the groups (Brida et al., 2011; Litvin et al., 2013). These conflicts can erupt as a result of second home owners' unwillingness

to interact with the permanent residents, the tendency of second home owners to buy homes in the areas where people of their own nationality reside (Honkanen, Pitkänen, & Hall, 2016), or the presence of social status differences among groups.

Increases in the demand for second homes can affect the architectural style of the local culture. Today's second homes feature modern designs, marked by exterior techniques and the use of high quality material, while the area surrounding the homes tend to undergo development so as to include recreational facilities, such as bathhouses, pools, spa centers, sports facilities, cinemas, shopping centers, etc. (Manisa & Görgülü, 2008). Second home ownership enables the coexistence of different cultures. However, these differences can result in cultural conflicts between residents and second home owners (Hoogendoorn et al., 2007). In the event that second home owners underestimate certain cultural values of the local community, residents are provoked into reacting, which in effect leads them to adopt negative attitudes towards second home owners. Moreover, the language barrier results in limitations in communication (Hiltunen, 2007).

Economic interaction

The presence of foreign owners generates a number of economic impacts on the destinations wherein they reside. These impacts can affect the residents not only positively but also negatively (Larsson & Müller, 2019). Second home owners buy homes for the purpose of having a place to spend their holidays and of making investments in other countries. During the periods in which the homes are not used, some owners rent them out, while others purchase the homes strictly for investment, renting them out and obtaining revenues via real estate companies (Koç, 1996).

The positive effects include the new business opportunities that arise from the increase in second home ownership (Farstad & Rye, 2013), the economic growth that occurs, especially in second home destinations that are in mountain regions and rural areas (Dadvar-Khani, 2019), the rise in demand on local products and the consequent rise in the revenues of the local residents (Brida et al., 2011; Roca et al., 2012), the development of new shopping facilities as a result of the higher demand for local products (Gallent, Mace, & Tewdwr-Jones, 2005), and lastly, the stimulation of the real estate sector, whereby new revenue-creating opportunities are created for residents (Kuentzel & Ramaswamy, 2005). On the other hand, the negative impacts of second home owners on the economic life of the community include housing price inflation in the areas heavily populated with second home owners (Gallent et al., 2005), the increase in real estate prices caused by the high demand for second homes and the resulting difficulty residents face in being able to buy homes (Cho, Newman, & Wear, 2003) and lastly, the displacement of the permanent residents due to the above stated reasons (Marjavaara & Müller, 2007).

Methodology

Study area

Alanya has a population of 312,319 (Turkey Statistical Institute, 2019), and is located in the Mediterranean region, 135 km away from Antalya. It is a city whose bed capacity is 176,993 and which received 4.6 million foreign tourists in 2018. This figure constituted 12% of the total number of foreign tourists who visited Turkey and 31% of the total number coming to Antalya (Alanya Chamber of Commerce and Industry [ACCI], 2019).

According to the available data, people from 90 different countries have 42,882 second homes in Alanya. Ranking them according to the countries with the highest number of second homes in the city, the Russian Federation is the first with 7,555 homes, Norway is the second with 5,875 homes, followed by Germany with 5,253 homes (Table 1). In 2018, 6,186 people from 74 different countries purchased a second home in Alanya. In addition, 20,619 new people from 112 different countries received an official residential permit in Alanya (ACCI, 2019).

Questionnaire design, sampling, and data collection

A quantitative research method was used in this study. The data were collected through a structured questionnaire comprised of three main sections. The first section addresses the characteristics of residents, the second—the home owners' impacts, and the third—the residents' level of satisfaction with living with second home owners. In the research, a scale was developed to determine the impacts of second home owners. The aim of the scale was to measure how the residents perceived second home owners' impacts on the socio-cultural and economic structure of the city. The development of the scale involved three distinct steps: initial item development, performance of a pilot study, and determination of the actual study sample.

To begin the research, a review was conducted on the empirical studies related to research subject in the literature. An item list was then formed with 100 items about the impacts of second home owners (Çavuş & Çolakoğlu, 2009; Çevirgen & Kesgin, 2007; Gündüz, 2003; Hiltunen, 2007; Müller et al., 2004; Oğuzhan & Bayezit, 2002; Öztürk Akdu, & Akdu, 2007; Üngüren & Doğan, 2010). English items obtained from foreign sources were translated into the Turkish language. Some items were added to the list by the researchers, including 3 satisfaction items. The items were prepared using a 5-point Likert-type scale, where 1 indicated "completely disagree" and 5 "completely agree".

Next, the questionnaire was formed. Firstly, the expressions that are in the same direction or whose meaning was unclear were removed. It featured 50 items to determine the second home owners' impacts and residents' demographic characteristics and levels of satisfaction. A pilot study was conducted using 50 randomly selected residents to determine whether or not the questions were incomprehensible or complicated. The reliability of the whole scale was then tested. Cronbach's alpha was found to be .739. After the completion of the first pilot study, the questions relevant to the impact and satisfaction were separated by the researchers. The second pilot study was conducted using 50 academicians. Cronbach's alpha on the impact scale was found to be .850, and the satisfaction scale's reliability was found to be .744. Finally, the questionnaire for the actual study was created and featured 46 items (36 items on the impact scale, three items on the satisfaction scale, and seven items on the residents' demographic characteristics).

Table 1
*Nationalities of foreign owners in Alanya
(The first ten countries)*

Country	Number of homes
Russian Federation	7,555
Norway	5,875
Germany	5,253
Denmark	3,956
Sweden	3,613
Netherlands	2,582
Finland	2,074
Ireland	1,626
Iraq	1,558
Iran	1,350

Note. Adapted from *Alanya Ekonomik Rapor 2018* [Alanya Economic Report 2018] by Alanya Chamber of Commerce and Industry, 2019 (<https://www.altso.org.tr/yayinlarimiz/alanya-ekonomik-rapor/alanya-ekonomik-rapor-2018/>).

A stratified random sampling technique was used to determine the sample for the study. The population of the research included Alanya Municipality and five districts connected to the city on the southeast. In order to gather data, a face to face survey was conducted with 460 residents. Seven questionnaires were discarded because of missing data. Consequently, 453 questionnaires were evaluated.

Respondents' profile

The respondents' profile is summarized in Table 2 which shows that 53.6% of the respondents were male, 31.1% between the ages of 26 and 33, 41.7% of the high school graduates, 64.5% residing in the center of Alanya, 54.9% living for less than 10 years in the city, 56.9% working in the tourism sector directly or indirectly, and 70.2% have a close relationship with second home owners in the form of neighborhood, friendship, and family relations. As a necessity of living together in the city, the remaining 29.8% are in a more general relationship with them—commercial, social, etc.

Table 2.
Respondents' profile

Categories	<i>N</i>	%	Categories	<i>N</i>	%
Gender			Educational level		
Male	243	53.6	Primary school	51	11.3
Female	210	46.4	Secondary school	83	18.3
Age			High school	189	41.7
18–25	127	28	Associate degree	51	11.3
26–33	141	31.1	Bachelor degree	77	17
34–41	99	21.9	Master/doctoral degree	2	0.4
42–49	52	11.5	Duration of residency (years)		
50 or over	34	7.5	Less than 1	18	4
Place of residence			1–5	113	24.9
Alanya	292	64.5	6–10	118	26
Cikcilli	28	6.2	11–15	72	15.9
Oba	41	9.1	16–20	33	7.3
Tosmur	16	3.5	21–25	31	6.8
Kestel	20	4.4	26 or over	68	15
Mahmutlar	56	12.4	Relation to the tourism sector		
Relationship status type			Direct	117	25.8
Continuous	111	24.5	Indirect	141	31.1
Partial	207	45.7	Never	86	19
None	135	29.8			

EFA and CFA results

In this exploratory study, EFA was conducted first in order to determine the dimensions of the perceptions of the local people. Thus, it was aimed to gather the perception measured by 32 questions under fewer factors. In addition, an answer to the first research question was sought. Then CFA was performed to verify the obtained factor structures. This enabled us to test whether there was a high correlation between the items. High correlations between items or factors lead to errors in Structural Equation Modeling (SEM). Therefore, these must be eliminated before analyzing the model. Using a small number of items in SEM is an important condition for more accurate results. Therefore, it is recommended to use a smaller number of factors instead of multi-item scales. Second-level CFA should be done in order to see and correct errors in factor structures. For this reason, this systematic approach was followed during the data analysis phase.

In the SHTIS, 8 items were eliminated because their factor loadings were under .50 and they did not create a significant factor structure during EFA. In the result of the analysis, a total of four factors were obtained: Economic Benefit (ECB), Socio-Cultural Cost (SCC), Socio-Cultural Benefit (SCB), and Economic Cost (ECC). The four factors explained 54.74% of the total variance (Table 3). The overall reliability of the scale is .849 (α) and KMO value is .905.

The results of the questionnaire showed that the residents felt that the foreign second home owners increased both economic costs ($M = 4.33$) and economic benefits ($M = 4.18$). It was also indicated that while their interaction with second home owners affected their socio-cultural life positively ($M = 4.07$), they were nonetheless anxious about the socio-cultural cost ($M = 3.24$). A CFA was conducted in order to confirm the factors obtained from the EFA (Table 3).

Table 3
 EFA&CFA results for SHTIS

Factors and Items	EFA Loading	CFA Loading	Mean	EFA (α)
Factor 1. Economic Benefit (ECB)			4.18	
E33 It* increases total tourism revenue	.823	.88	4.21	
E34 It increases financial resources of municipalities	.771	.92	4.16	
E25 It creates new job opportunities	.761	.7	4.08	
E24 It increases shopping opportunities	.725	.76	4.07	
E35 It contributes to the international recognition of Alanya	.724	.923	4.31	.921
E27 It increases revenue of tourism companies	.714	.79	4.16	
E32 It lengthens the duration of tourism season	.695	.87	4.17	
E36 It provides economic benefits to residents	.686	.087	4.25	

Table 3
 Continued

Factors and Items	EFA Loading	CFA Loading	Mean	EFA (α)
Factor 2. Socio-Cultural Cost (SCC)			3.24	
C4 It undermines residents' spiritual values	.717	.6	3.3	
S17 It causes negative changes in family life	.689	.66	2.74	
C3 It increases unethical behaviors in the community	.682	.59	3.35	
C6 It spoils cultural integrity by increasing admiration of foreign cultures	.661	.65	3.27	
C11 It undermines the music culture	.648	.68	3.42	.848
C10 It affects the food culture negatively	.622	.71	2.86	
S16 It corrupts residents' daily language	.62	.7	3.16	
S22 It causes the debasement of local dress code	.618	.598	3.26	
S21 It negatively changes the understanding of marriage	.599	.594	3.2	
S19 It increases the alcohol consumption of the residents	.544	.566	3.27	
Factor 3. Socio-Cultural Benefit (SCB)			4.07	
C7 It increases international artistic and cultural events	.718	.83	4.1	
S13 It contributes to the modernization of the city	.699	.8	4.09	
C8 It improves the architectural style positively	.698	.77	3.81	.832
C5 It increases the education and cultural level	.649	.74	3.81	
S18 It creates new leisure and recreational facilities	.63	.74	4.23	
S23 It encourages the learning of foreign languages	.613	.69	4.39	
Factor 4. Economic Cost (ECC)			4.33	
E29 It increases the office rents	.854	.901	4.35	
E30 It increases the house rents	.843	.95	4.36	.921
E28 It increases the home prices	.824	.89	4.37	
E31 It raises the cost of living	.752	.87	4.27	

Note. *It = Second home tourism.

As the first level CFA goodness-of-fit was determined to be at an acceptable level, the four factors obtained as a result of the EFA were confirmed. More details are presented in Table 4.

Table 4
The first level CFA Goodness-of-fit Indexes for SHTIS

Indexes	Chi-square (χ^2)	χ^2/df	RMSEA	GFI	AGFI	CFI	RMR	SRMR
Values	733.22	2.50	0.059	0.92	0.86	0.99	0.094	0.081
Status	Significant	Acceptable	Good	Acceptable	Low	Good	Acceptable	Acceptable

According to the second level CFA results, the fit indices of the model built on factor structures are valid (Table 5). There is no correlation error between the factors. Thus, it was verified that suitable conditions were provided for SEM.

Table 5
The second level CFA Goodness-of-fit Indexes for SHTIS

Indexes	Chi-square (χ^2)	χ^2/df	RMSEA	GFI	AGFI	CFI	RMR	SRMR
Values	657.49	2.24	0.047	0.92	0.88	0.98	0.087	0.073
Status	Significant	Acceptable	Good	Acceptable	Low	Good	Acceptable	Acceptable

The items on the satisfaction scale were gathered together under one factor, designated as Satisfaction (SAT), as a result of EFA. This one factor explained 84.52% of the total variance (Table 6). The general satisfaction of the local people is low ($M = 2.81$). While the residents were found not to be dissatisfied with second home owners ($M = 3.11$), they nonetheless did not want them to have more homes ($M = 2.71$) or have the benefit of more flexible conditions for buying homes ($M = 2.61$). Thus, the answer to the second research question has been reached.

Table 6.
EFA results for satisfaction scale

Items	Factor Loading	Eigen-Value	Mean	Alpha (α)
Satisfaction (SAT)		2.53	2.81	
S1 I am satisfied with living with second home owners	0.944		3.11	
S2 If I were authorised, I would make the conditions of foreign estate ownership more flexible	0.937		2.61	.908
S3 I am pleased that more foreigners buy homes in our city	0.875		2.71	
Total Variance Explained (%)			84.527	
KMO			0,720	

Note. Bartlett's Test of Sphericity 966.022 (Dif. 496; Sig. 0.000).

Correlation and structural equation modeling

A correlation analysis was performed to determine the relations between SHTIS factors and SAT factor (Table 7). According to analysis results, the factors with the highest relationship between them were ECB and SCB ($r = .600$; $p < .01$). There was a significant, positive relation between ECB

and SCB. There was a significant, negative relation between ECB and ECC ($r = -0.526$; $p < .01$) and finally, no significant relation between ECC and SAT ($r = .050$; $p > .01$).

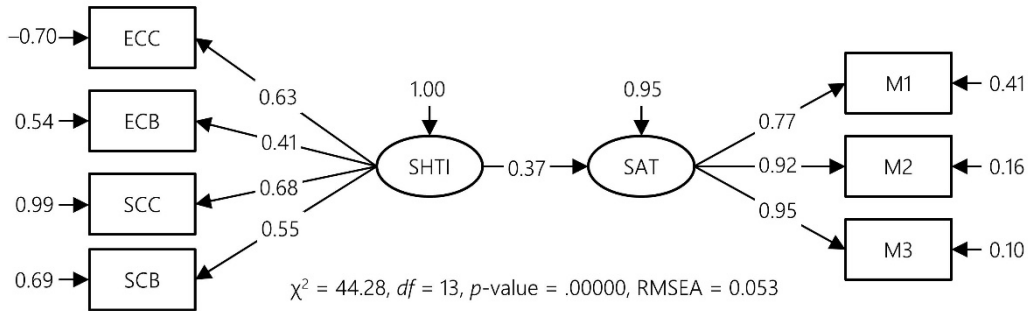

Figure 1. Research model.

A SEM analysis was performed to determine the impact of SHTIS factors on SAT (Figure 1). As a result of this analysis, fit indicators were found to be significant ($\chi^2/df = 3.40$; $RMSEA = 0.053$; $AGFI = 0.90$; $GFI = 0.93$; $CFI = 0.90$). Second home tourism has a positive effect on SAT. As a result, second home tourism is a significant predictor of SAT.

Table 7

Correlation analysis results

Factors	1. ECB	2. SCB	3. ECC	4. SCC	5. SAT
1. ECB	1				
2. SCB	.600*	1			
3. ECC	-.526*	-.315*	1		
4. SCC	-.186*	-.239*	.141*	1	
5. SAT	.248*	.208*	.050	-.312*	1

Note. *significant at the .01 level.

Table 8

Structural equations models' paths

Independent Variables	Dependent Variable	β	R^2	t
ECC	SAT	-.74	.64	11.98
ECB		.65	.20	9.71
SCC		-.78	.58	10.67
SCB		.57	.49	10.52

SCC is the most important predictor of the SAT factor ($\beta = -0.78$; $t = 10.67$). ECC is the second important determinant ($\beta = -0.74$; $t = 11.98$). ECB ($\beta = 0.65$; $t = 9.71$) and SCB ($\beta = 0.57$; $t = 10.52$) are determined as other important predictors.

Findings show that local people prioritize negative impacts. Although there is no big difference between them, the negativities felt in the socio-cultural sphere are a little more a priority than the negativity in the economic sphere (Table 8). The third research question was also answered with the data obtained.

Conclusion

The results of the study showed that the presence of foreign second home owners had socio-cultural and economic impacts on the city's life. From the analyses, it was clear that the residents perceived these impacts on different levels.

In terms of SHTIS, the residents felt that the presence of foreign second home owners in Alanya had economic costs, such as rise in the cost of living and the increase in home prices as well as socio-cultural costs, such as an undermining influence on spiritual values and the corruption of the local culture. The residents did, however, also indicate that the development of second homes in

the region created certain economic and socio-cultural benefits, such as new employment opportunities and shopping options, the extension of the tourist season, new leisure and recreational facilities, and an opportunity for local residents to learn foreign languages. The findings show that the negative perceptions of the local people in terms of economy and their positive perceptions in socio-cultural terms are high.

As for the questions related to the levels of satisfaction, the residents indicated that they were not dissatisfied with living with foreign second home owners, but only that they did not want them to have more homes or more flexible conditions to buy them (Casado-Diaz, Casado-Diaz, & Hoogendoorn, 2020; Paris, 2018). These responses suggest that the residents harbored anxiety about the prospect of foreigners having more estates in their area (Golmohammadi, 2019). A positive relation was observed between residents' satisfaction level and economic and socio-cultural benefit perceptions related to the impacts that foreign second home owners had on the city's life (D' Emery, Pinto, & Almeida, 2018). On the other hand, a negative relation was seen between residents' satisfaction level and their socio-cultural cost perceptions.

The most important factor affecting the residents' satisfaction level was socio-cultural cost, a finding suggesting that residents placed greater importance on the socio-cultural cost than on the other factors. Another important factor affecting the satisfaction of local people is economic costs. The cost to the city's economy derived by foreign owners of second homes had a negative impact on the residents' perspectives of them. Although ECB and SCB are also effective on satisfaction, it is seen that negative effects are more prominent. This is an expected result. In destinations where tourism has just begun to develop, the economic benefits of tourism are at the forefront for residents. Social, cultural and economic problems begin to emerge as a result of the growth of tourism activities. Thus, doubts arise among the local people about the long-term benefits of tourism. Initially, the positive attitude toward tourism starts to change negatively (Butler, 1980).

In cases where the residents' satisfaction level decreases, it is possible that there is disagreement between second home owners and residents (Mirabolghasemi, 2019). Therefore, it is necessary to build second homes according to a detailed plan and to take into account the balance between the populations of foreign owners and residents (Back & Marjavaara, 2017). Otherwise, the increasing number of foreigners can create pressure on the residents and lead to the socio-cultural degradation of the local community, which in turn can possibly jeopardize the socio-cultural structure of the society and result in the increase of anxiety for future generations (Rudsari & Gharibi, 2018).

Second home tourism depends on voluntary immigration. As a result of this, people from different cultures live together with the local residents in the same economic and socio-cultural structure. This situation may cause some communication disconnections, incompatibilities, and conflicts between cultures. For different societies to be integrated with each other, it is important to establish the right communication channels and develop social policies for the culture of living together. Policy makers, local authorities, non-governmental organizations (NGOs), and other related stakeholders in the society should work together to raise the awareness of local people living with foreign cultures. The foreigners' associations need to cooperate with local authorities and NGOs, and manage activities in such a way as to increase the residents' participation in the associations. In this way, the negative perceptions harbored by the residents' can be dissolved and both sides can be drawn closer to one another. All these actions are important for the sustainable development of secondary housing tourism in the region.

Limitations and implications

The study was conducted with permanent residents only and did not involve second home owners, local authorities, NGOs, or tourism companies. Moreover, the study focused strictly on the socio-cultural and economic impacts of second home owners, disregarding the environmental impacts on account of the fact that the number of second home owners was too small to have a significant impact on the environment. Looking at this particular issue of environmental impact more broadly, the important question to ask is whether the destination is managed well or not, as the large-scale, fast and relatively unplanned development of second home tourism can bring the risk of spoilage of the local eco-system and cause environmental pollution (Müller, 2002b; Radulescu, 2014). The planned development of second homes, in harmony with the laws and the environment, minimizes the possible negative environmental impacts.

For future studies, it is recommended to determine what kind of anxieties the residents have toward foreign ownership, to conduct research about other factors affecting the residents' satisfaction with living with second home owners, determine the impacts of foreign ownership on the residents' quality of life, determine the other stakeholders' perspectives toward foreign ownership, and encourage similar studies in different areas of Turkey, the Mediterranean region and the world where second homes have been developing. As a conclusion, this study was conducted before the COVID-19 pandemic. Therefore, it is recommended to determine whether there has been any change in the perceptions of residents toward the settled foreigners during the pandemic process.

Acknowledgements

This article is based on a master's thesis produced by Furkan Baltaci under the direction of Aydin Cevirgen at Akdeniz University in Antalya-Turkey. Retrieved from https://tez.yok.gov.tr/UlusalTezMerkezi/TezGoster?key=zD1B0cW7zVr3VcnZjitVXs4D_N7_WWGGGCmOa6CzCNfbOXFuO8Ys4iCLWDJo4L-J

References

- Abdul-Aziz, A. R., Loh, C. L., & Jaafar, M. (2014). Malaysia's my second home (MMSH) programme: an examination of Malaysia as a destination for international retirees. *Tourism Management*, 40, 203–212. <https://doi.org/10.1016/j.tourman.2013.06.008>
- Alanya Chamber of Commerce and Industry. (2019). *Alanya Ekonomik Rapor 2018* [Alanya Economic Report 2018]. Retrieved from <https://www.altso.org.tr/yayinlarimiz/alanya-ekonomik-rapor/alanya-ekonomik-rapor-2018/>
- Adamiak, C. (2018). Changing social structure of second home owners in Poland. In C. M. Hall & D. K. Müller (Eds.), *The Routledge handbook of second home tourism and mobilities* (pp. 201–211). Abingdon, UK: Routledge.
- Back, A., & Marjavaara, R. (2017). Mapping an invisible population: the uneven geography of second-home tourism. *Tourism Geographies*, 19(4), 595–611. <https://doi.org/10.1080/14616688.2017.1331260>
- Barnett, J. (2014). Host community perceptions of the contributions of second homes. *Annals of Leisure Research*, 17(1), 10–26. <https://doi.org/10.1080/11745398.2014.886156>
- Baud-Bovy, M., & Lawson, F. R. (1977). *Tourism and recreation development*. London, UK: The Architectural Press.
- Breuer, T. (2005). Retirement migration or rather second-home tourism? German Senior Citizens on the Canary Islands. *Contributions to Human Geography*, 136(3), 313–333. Retrieved from https://epub.uni-regensburg.de/1114/1/JPG-313-333_neu.pdf
- Brida, J. G., Osti, L., & Santifaller, E. (2011). Second homes and the need for policy planning. *TOURISMOS: An International Multidisciplinary Journal of Tourism*, 6(1), 141–163. Retrieved from https://papers.ssrn.com/sol3/papers.cfm?abstract_id=1468422

- Butler, R. W. (1980). The concept of a tourist area cycle of evolution: Implications for management of resources. *Canadian Geographer/Le Géographe canadien*, 24(1), 5–12. Retrieved from http://www.numptynerd.net/uploads/1/2/0/6/12061984/butler_model_1980.pdf
- Casado-Díaz, M. A., Casado-Díaz, A. B., & Hoogendoorn, G. (2020). The home exchange phenomenon in the sharing economy: a research agenda. *Scandinavian Journal of Hospitality and Tourism*, 20(3), 268–285. <https://doi.org/10.1080/15022250.2019.1708455>
- Cho, S. H., Newman, D. H., & Wear, D. N. (2003). Impact of second home development on housing prices in the Southern Appalachian highlands. *Review of Urban & Regional Development Studies*, 15(3), 208–225. Retrieved from https://www.srs.fs.fed.us/pubs/ja/ja_cho005.pdf
- Çavuş, Ş., & Çolakoğlu, O. E. (2009). Kuşadası ve Didim halkının yabancıların gayrimenkul edinmelerinin turizme etkilerini algılaması [Perceptions of the people of Kuşadası and Didim on the effects of foreigners' property acquisition on tourism]. In *10th National Tourism Congress Proceedings Book* (pp. 1265–1286), Ankara, Turkey: Detay Publishing.
- Çevirgen, A., & Kesgin, M. (2007). Local authorities' and NGOs' perceptions of tourism development and urbanization in Alanya. *Tourism: An International Interdisciplinary Journal*, 55(3), 309–322. Retrieved from <https://hrcak.srce.hr/24651>
- Dadvar-Khani, F. (2019). Second home tourism and agriculture in rural areas: examining the effects of second homes on agricultural resources in northern Iran. *Journal of Rural Development*, 38(1), 123–143. <https://doi.org/10.25175/jrd/2019/v38/i1/111715>
- D' Emery, R., Pinto, H., & Almeida, C. R. (2018). Governance networks and second home tourism: Insights from a Sun and Sea Destination. *Journal of Spatial and Organizational Dynamics*, 6(4), 375–391. Retrieved from <https://www.jsod-cieo.net/journal/index.php/jsod/article/view/158>
- Dias, A. J., Correia, A., & Lopez, F. J. M. (2015). The meaning of rental second homes and places: the owners' perspectives. *Tourism Geographies*, 17(2), 244–261. <https://doi.org/10.1080/14616688.2014.959992>
- Farstad, M. (2011). Rural residents' opinions about second home owners' pursuit of own interests in the host community. *Norsk Geografisk Tidsskrift - Norwegian Journal of Geography*, 65(3), 165–174. <https://doi.org/10.1080/00291951.2011.598551>
- Farstad, M. (2018). The moral dilemma of second home owners' position in the host community. In C. M. Hall & D. K. Müller (Eds.), *The Routledge handbook of second home tourism and mobilities* (pp. 258–266). Abingdon, UK: Routledge.
- Farstad, M., & Rye, J. F. (2013). Second home owners, locals and their perspectives on rural development. *Journal of Rural Studies*, 30, 41–51. <https://doi.org/10.1016/j.jrurstud.2012.11.007>
- Gallent, N. (2014). The social value of second homes in rural communities. *Housing, Theory and Society*, 31(2), 174–191. <https://doi.org/10.1080/14036096.2013.830986>
- Gallent, N., Mace, A., & Tewdwr-Jones, M. T. (2005). *Second homes: European perspectives and UK policies*. Aldershot, UK: Ashgate.
- Golmohammadi, F. (2019). A viewpoint toward second houses in rural regions of Iran: Situations and problems. *Black Sea Journal of Public and Social Science*, 2(1), 1–15. Retrieved from <https://dergipark.org.tr/en/download/article-file/599759>
- Gündüz, E. (2003). *Tatil amaçlı ikinci konutların fiziksel ve sosyal yapıya etkileri: Mahmutlar örneği [Effects of second holiday homes on physical and social structure: A case of Mahmutlar]* (Unpublished Master Thesis) Selçuk University Institute of Natural & Applied Sciences, Konya, Turkey.
- Hall, C. M., & Müller, D. K. (2004). Introduction: second homes, curse or blessing? Revisited. In C. M. Hall & D. K. Müller (Eds.), *Tourism, mobility, and second homes: between elite landscape and common ground* (pp. 3–14). Clevedon, UK: Channel View Publications.
- Hiltunen, M. J. (2007). Environmental impacts of rural second home tourism – Case Lake District in Finland. *Scandinavian Journal of Hospitality and Tourism*, 7(3), 243–265. <https://doi.org/10.1080/15022250701312335>
- Honkanen, A., Pitkänen, K., & Hall, M. C. (2016). A local perspective on cross-border tourism. Russian second home ownership in Eastern Finland. *International Journal of Tourism Research*, 18(2), 149–158. <https://doi.org/10.1002/jtr.2041>

- Hoogendoorn, G., Mellett, R., & Visser, G. (2007). Second homes tourism in Africa: Reflections on the South African experience. In C. M. Rogerson & G. Visser (Eds.), *Urban tourism in the developing world* (pp. 127–166). Piscataway, NJ: Transaction Publishers.
- Jaakson, R. (1986). Second-home domestic tourism. *Annals of Tourism Research*, 13(3), 367–391. [https://doi.org/10.1016/0160-7383\(86\)90026-5](https://doi.org/10.1016/0160-7383(86)90026-5)
- Kaltenborn, B. P., Andersen, O., Nelleman, C., Bjerke, T., & Thrane, C. (2008). Resident attitudes towards mountain second-home tourism development in Norway: the effect of environmental attitudes. *Journal of Sustainable Tourism*, 16(6), 664–680. <https://doi.org/10.1080/09669580802159685>
- Koç, H. (1996). *Türkiye’de kıyı yerleşmelerinde tatil konutları* [Holiday houses in coastal settlements in Turkey]. Mass Housing Administration Housing Series: 17, Ankara, Turkey: ODTÜ Press.
- Kuentzel, W. F., & Ramaswamy, V. M. (2005). Tourism and amenity migration a longitudinal analysis. *Annals of Tourism Research*, 32(2), 419–438. <https://doi.org/10.1016/j.annals.2004.06.008>
- Lanzara, G., & Minerva, G. A. (2019). Tourism, amenities, and welfare in an urban setting. *Journal of Regional Science*, 59(3), 452–479. <https://doi.org/10.1111/jors.12440>
- Larsson, L., & Müller, D. K. (2019). Coping with second home tourism: responses and strategies of private and public service providers in western Sweden. *Current Issues in Tourism*, 22(16), 1958–1974. <https://doi.org/10.1080/13683500.2017.1411339>
- Litvin, S. W., Xu, G., Ferguson, A. C., & Smith, W. W. (2013). Too attractive for its own good? South of broad, second/vacation-homes and resident attitudes. *Tourism Management Perspectives*, 7, 89–98. <https://doi.org/10.1016/j.tmp.2013.04.003>
- Manisa, K., & Görgülü, T. (2008). İkincil konutların turizm sektöründe yeniden kullanılabilmesine ilişkin bir model [A model on reusing of secondary housing in the tourism sector]. *Megaron Yıldız Technical University Faculty of Architecture E-Journal*, 3(1), 68–78. Retrieved from <https://megaronjournal.com/jvi.aspx?pdire=megaron&plng=eng&un=MEGARON-85856>
- Marjavaara, R., & Müller, D. K. (2007). The development of second homes' assessed property values in Sweden 1991–2001. *Scandinavian Journal of Hospitality and Tourism*, 7(3), 202–222. <https://doi.org/10.1080/1502250601160305>
- McLeod, B., & Busser, J. A. (2014). Second home owners hosting friends and relatives. *Annals of Leisure Research*, 17(1), 86–96. <https://doi.org/10.1080/11745398.2014.888955>
- Mirabolghasemi, S. M. (2019). Impacts of second home tourism on restructuring rural settlements: A case study on Foudije Village, Bahabad County. *Iranian Journal of Tourism & Hospitality*, 6(3), 53–68. Retrieved from <https://www.sid.ir/en/journal/ViewPaper.aspx?ID=683741>
- Müller, D. K. (2002a). Reinventing the countryside: German second-home owners in Southern Sweden. *Current Issues in Tourism*, 5(5), 426–446. <https://doi.org/10.1080/13683500208667933>
- Müller, D. K. (2002b). Second home ownership and sustainable development in Northern Sweden. *Tourism and Hospitality Research*, 3(4), 343–355. <https://doi.org/10.1177/146735840200300406>
- Müller, D. K. (2006). The attractiveness of second home areas in Sweden: A quantitative analysis. *Current Issues in Tourism*, 9(4–5), 335–350. <https://doi.org/10.2167/cit269.0>
- Müller, D. K. (2007). Second homes in the Nordic countries: Between common heritage and exclusive commodity. *Scandinavian Journal of Hospitality and Management*, 7(3), 193–201. <https://doi.org/10.1080/1502250701300272>
- Müller, D. K. (2011a). Second homes in rural areas: Reflections on a troubled history. *Norsk Geografisk Tidsskrift - Norwegian Journal of Geography*, 65(3), 137–143. <https://doi.org/10.1080/00291951.2011.597872>
- Müller, D. K. (2011b). The Internationalization of rural municipalities: Norwegian second home owners in Northern Bohuslan, Sweden. *Tourism Planning & Development*, 8(4), 433–445. <https://doi.org/10.1080/21568316.2011.605384>
- Müller, D. K., Hall, C. M., & Keen, D. (2004). Second home tourism impact, planning and management. In C. M. Hall & D. K. Müller (Eds.), *Tourism, mobility, and second homes: Between elite landscape and common ground* (pp. 15–32). Clevedon, UK: Channel View Publications.
- Müller, D. K., & Hoogendoorn, G. (2013). Second homes: Curse or blessing? A review 36 years later. *Scandinavian Journal of Hospitality and Tourism*, 13(4), 353–369. <https://doi.org/10.1080/1502250.2013.860306>

- Newig, J. (2000). Freizeitwohnen: mobil und stationär [Leisure living: mobile and stationary]. In *Nationalatlas Bundesrepublik Deutschland: freizeit und tourismus* [National Atlas of the Federal Republic of Germany: leisure and tourism] (pp. 68–71). Retrieved from http://archiv.nationalatlas.de/wp-content/art_pdf/Band10_68-71_archiv.pdf
- Norris, M., & Winston, N. (2010). Second-home owners: escaping, investing or retiring? *Tourism Geographies*, 12(4), 546–567. <https://doi.org/10.1080/14616688.2010.516401>
- Nouza, M., Ólafsdóttir, R., & Müller, D. K. (2013). A new approach to spatial–temporal development of second homes: case study from Iceland. *Scandinavian Journal of Hospitality and Tourism*, 13(1), 20–37. <https://doi.org/10.1080/15022250.2013.764512>
- Nouza, M., Ólafsdóttir, R., & Sæþórsdóttir, A. D. (2018). Motives and behaviour of second home owners in Iceland reflected by place attachment. *Current Issues in Tourism*, 21(2), 225–242. <https://doi.org/10.1080/13683500.2015.1072139>
- Oğuzhan, A., & Bayezit, D. (2002). Trakya'da Turizm Sektöründeki Yazlık Konutların Çevresel ve Sosyal Etkileri [Environmental and Social Impacts of Summer Homes in the Tourism Sector in Trakya]. *Trakya University Journal of Scientific Research*, 2(1), 65–71. Retrieved from <https://app.trdizin.gov.tr//makale/TWpNM016TT0/%20trakya-da-turizm-sektorundeki-yazlik-konutlarin-cevresel-ve-sosyal-etkileri>
- Overvåg, K. (2011). Second homes: migration or circulation? *Norsk Geografisk Tidsskrift – Norwegian Journal of Geography*, 65(3), 154–164. <https://doi.org/10.1080/00291951.2011.598237>
- Öztürk, Y., Akdu, U., & Akdu, S. A. (2007). Yabancı turistlerin konut/devre mülk satın almalarının yöre halkı üzerindeki sosyal ve kültürel etkileri: Fethiye örneği [A case study on tourism's social and cultural degeneration as a result of marketing estate/timesharing to foreign tourists in Fethiye]. *Journal of Commerce & Tourism Education Faculty*, 2, 11–29. Retrieved from <https://dergipark.org.tr/tr/download/article-file/842717>
- Paris, C. (2018). Australian holiday homes: Places of escape and sites of investment. In C. M. Hall & D. K. Müller (Eds.), *The Routledge handbook of second home tourism and mobilities* (pp. 152–166). Abingdon, UK: Routledge.
- Perles-Ribes, J. F., Ramón-Rodríguez, A. B., Moreno-Izquierdo, L., & Such-Devesa, M. J. (2020). Tourism competitiveness and the well-being of residents: a debate on registered and non-registered accommodation establishments. *European Journal of Tourism Research*, 24, 2406. Retrieved from <http://rua.ua.es/dspace/handle/10045/102209>
- Podra, O., Levkiv, H., Koval, G., Petryshyn, N. & Bobko, U. (2020). The impact of migration processes on the economy of Ukraine: Trends, reasons, consequences. *Journal of the Geographical Institute "Jovan Cvijić" SASA*, 70(2), 171–179. <https://doi.org/10.2298/IJGI2002171P>
- Radulescu, M. A. (2014). *The impact of second home tourism: A local residents' perspective: A case study on Cheia, Romania*. (Unpublished master's thesis). MSc Planet Europe: European Spatial Planning, Environmental Policy and Regional Development, Radboud University, Nijmegen, Netherlands & Cardiff University, Cardiff, UK.
- Roca, M. N. O., Oliviera, J., Roca, Z., & Costa, L. (2012). Second home tourism in the Oeste Region, Portugal: features and impacts. *European Journal of Tourism: Hospitality and Recreation*, 3(2), 35–55. Retrieved from http://www.optimeios.com/back/fotos/ejth2138/documentos/EJTHR_Vol3_2_Art2_Roca_et_al.pdf
- Rudsari, S. M. M., & Gharibi, N. (2018). Host attitude toward second home tourism impacts on rural development (The case of: Rural collection of Javaherdeh in Ramsar). *Iranian Journal of Tourism & Hospitality Research*, 5(4), 49–64. Retrieved from <https://www.sid.ir/en/journal/ViewPaper.aspx?ID=648961>
- Soto, M. T. R., & Clavé, S. A. (2018). The role of second homes in a Mediterranean coastal mass tourism destination: An evolutionary perspective. In C. M. Hall & D. K. Müller (Eds.), *The Routledge handbook of second home tourism and mobilities* (pp. 27–38). Abingdon, UK: Routledge.
- Statista. (2018). Number of nights spent by inbound visitors to the United Kingdom (UK) in 2018, by type of accommodation. Retrieved from <https://www.statista.com/statistics/512208/inbound-visitors-overnight-stays-by-accommodation-used-united-kingdom-uk/>
- Tress, G. (2002). Development of second-home tourism in Denmark. *Scandinavian Journal of Hospitality and Tourism*, 2(2), 109–122. <https://doi.org/10.1080/15022250216289>
- Turkey Statistical Institute. (2019). Adrese Dayalı Nüfus Kayıt Sistemi (ADNKS) Sonuçları [Address Based Population Registration System (ABPRS) Results]. Retrieved from http://www.tuik.gov.tr/PreTablo.do?alt_id=1059

- Tuulentie, S., & Kietäväinen, A. (2020). New rural community? Narratives from second home owners about everyday life in a tourist region in Finnish Lapland. *Sociologia Ruralis*, 60(2), 357–374. <https://doi.org/10.1111/soru.12288>
- Üngüren, E., & Dogan, H. (2010). Alanya Halkı'nın Turizme sosyo-kültürel açıdan bakışı [Perceptions of Alanya community for the socio-cultural effects of tourism]. *NWSA e-Journal of New World Sciences Academy*, 5(4), 396–415. Retrieved from <https://dergipark.org.tr/en/pub/nwsahuman/issue/19933/213312>
- Van Hear, N., Bakewell, O. & Long, K. (2018). Push-pull plus: Reconsidering the drivers of migration. *Journal of Ethnic and Migration Studies*, 44(6), 927–944. <https://doi.org/10.1080/1369183X.2017.1384135>
- Williams, A. M., King, R., Warnes, A., & Patterson, G. (2000). Tourism and international retirement migration: new forms of an old relationship in Southern Europe. *Tourism Geographies*, 2(1), 28–49. <https://doi.org/10.1080/146166800363439>
- Wong, B. K. M., & Musa, G. (2017). Malaysia my second home (MM2H): Retirees' demographic profile and spending dynamics. *Tourism Management*, 60, 42–46. <https://doi.org/10.1016/j.tourman.2016.11.012>